



**TEST & MEASUREMENT PRODUCTS**



**TEB110**  
**Product Manual**

## TABLE OF CONTENTS:

- Introduction.....3
- Sensor Installation .....4
- Operation .....7
- Recalibration Services .....8
- Warranty & Return Information .....8



## INTRODUCTION:

CTC Test and Measurement Sensors are extremely lightweight, shear mode accelerometers designed for research and development needs. PZT ceramic sensing elements are utilized to provide the highest signal to noise ratio available. The TEB110 is a 100 mV/g top exit accelerometer with a 10-32 coaxial connector.

### Key features

- Sensitivity: 100 mV/g
- Frequency Response ( $\pm 3$  dB): 0.5 Hz – 30 kHz
- Dynamic Range:  $\pm 50$  g, peak
- Power Requirements Voltage Source: 18-30 VDC
- Temperature Range: -58 to 250 °F
- Case Material: Titanium
- Connector: 10-32
- Max Temp: 250 °F (121 °C)
- Weight: .035 oz (10 g)

Please see the datasheet for additional technical specifications.

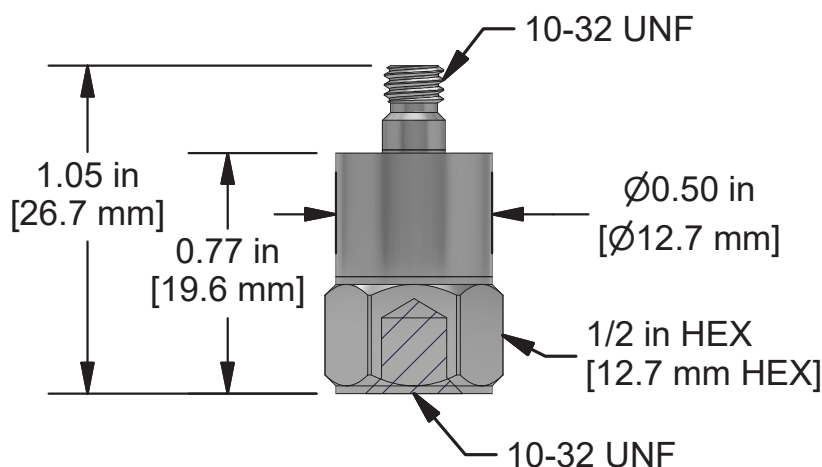

# SENSOR INSTALLATION

## Stud Mounting

Recommended application: Stud mounting is recommended for permanent installations and when testing at high frequencies. For this mounting technique, smooth flat surfaces are required.

1. Drill and tap a mounting hole in the desired location. The hole should be at least 1½ times the diameter of the desired mounting stud. For a 10-32 thread this equals approximately .240 in.  
Suggested installation tool: MH117-9A or MH117-9B
2. Clean the mounting surface and apply a light layer of grease, film, or coupling fluid to enhance vibration transmissibility.  
**Please note:** Epoxy can be substituted for semi-permanent mounting.
3. Screw the mounting stud into the base of the accelerometer.
4. Screw the sensor into the tapped hole. Use a torque wrench to ensure the sensor is adequately coupled to the mounting surface. The proper mounting torque is 1.5-2.5 ft. lbs (2,0 to 3,4 Nm).



**Figure 1. Stud Mounted Sensor**

# SENSOR INSTALLATION

## Adhesive Mounting

Recommended application: Adhesive mounting is recommended for portable applications or when the mounting surface is not adequate for stud mounting.

1. Prepare flat surface (32  $\mu$ in) and drill pilot hole for tapping with CTC MH117-2A or MH117-2B spot face tool ( $\perp$  0.003).
2. Screw the sensor into the adhesive mounting base.
3. Place a small portion of the adhesive onto the underside of the mounting base. Firmly press down. Remove any excess adhesive displaced around the base.
4. Recommended adhesive: CTC beeswax for temporary mounting or CTC MH109-2A epoxy for more permanent applications.



**Figure 2. Adhesive Mounted Sensor**

## Adhesive Mount Removal

1. If beeswax was used, gently remove the accelerometer.
2. If any adhesive other than beeswax was used, use a debonding agent to avoid damage. Apply the debonding agent and allow several minutes for it to penetrate the adhesive. Use a gentle, twisting motion to remove the sensor from the test structure.

# SENSOR INSTALLATION

## Magnetic Mounting

Recommended application: Magnetic mounting is recommended for nonpermanent installations.

1. Screw the accelerometer into the magnetic mounting base.
2. Apply the magnet to the mounting surface. To avoid damage to the sensor, gently rock, or slide the magnet into place to avoid slamming the magnet and shocking the sensor.

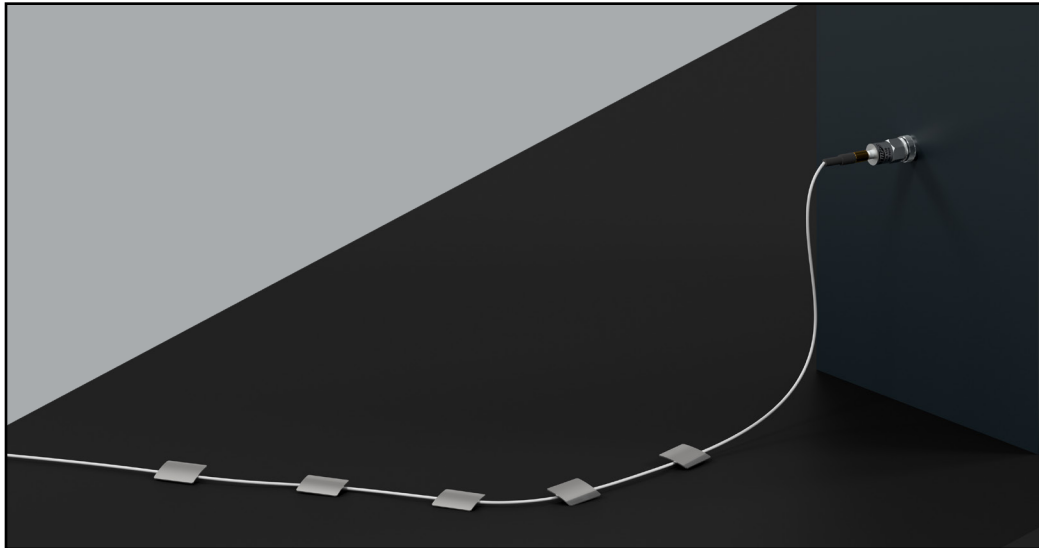

***Figure 3. Magnetic Mounted Sensor***

## OPERATION

1. Connect appropriate TMP cable and connector to your mounted sensor.
2. Route the cable to the power supply or the signal conditioner, ensuring there is no stress on the sensor/cable connection.

**Please note:** securing the cable with tape or clamps at regular intervals is suggested to minimize cable movement.



3. Turn on the power supply or signal conditioner.  
**Please note:** CTC sensors will function well with a constant current power unit, which provides 2-10 mA with a DC voltage level between 18 and 30 Vdc. We recommend using a current source of 2 mA and 24 Vdc. This can be provided by using a data collection device or by an interface circuit.

## **RECALIBRATION SERVICE**

CTC offers recalibration services for all TMP sensors. While sensors are extremely stable under normal conditions, we recommend a recalibration cycle of 12 months to ensure the highest accuracy. For recalibration services, fill out an RMA form on our website or contact your sales representative.

## **WARRANTY & REFUND**

### **Warranty**

All TMP products are backed by a five-year warranty on materials & workmanship for standard sensors, a three-year warranty on materials and workmanship for all accessories, cables, connectors, and custom products or private-labeled products.

### **Refund**

All stock products qualify for a full refund if returned in new condition within 90 days of shipment. Build to order products qualify for a 50% refund if returned in new condition within 90 days of shipment. Custom products are quoted and built specifically to the requirements of the customer, which may include completely custom product designs or private-labeled versions of standard products for OEM customers. Custom products ordered are non-cancellable, non-returnable, and non-refundable.

