

REVISIONS

REV.	ECN	DESCRIPTION	BY/DATE	CHK	APPR
A	4999	INITIAL RELEASE	JS 01/15/08	PA	PML

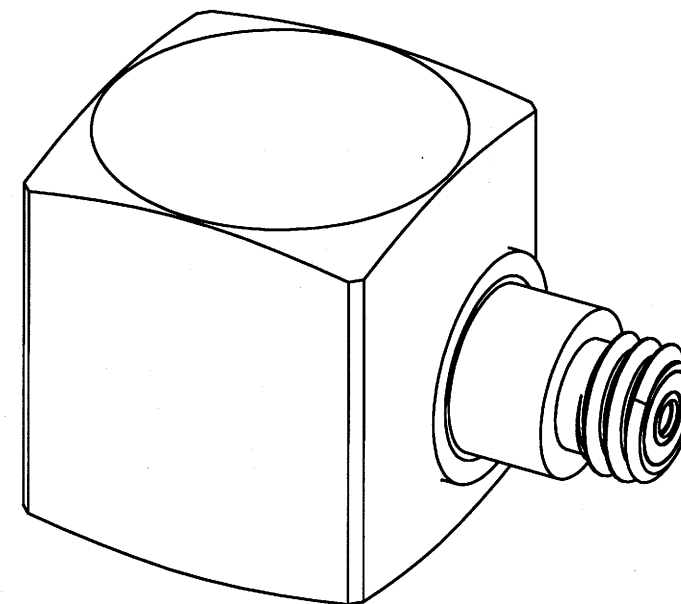

MODEL NO	REV	DATE	SENS
3214A1T	A	1/15/2008	10mV/g
3214A2T	A	1/15/2008	100mV/g
3214A3T	A	1/15/2008	500mV/g

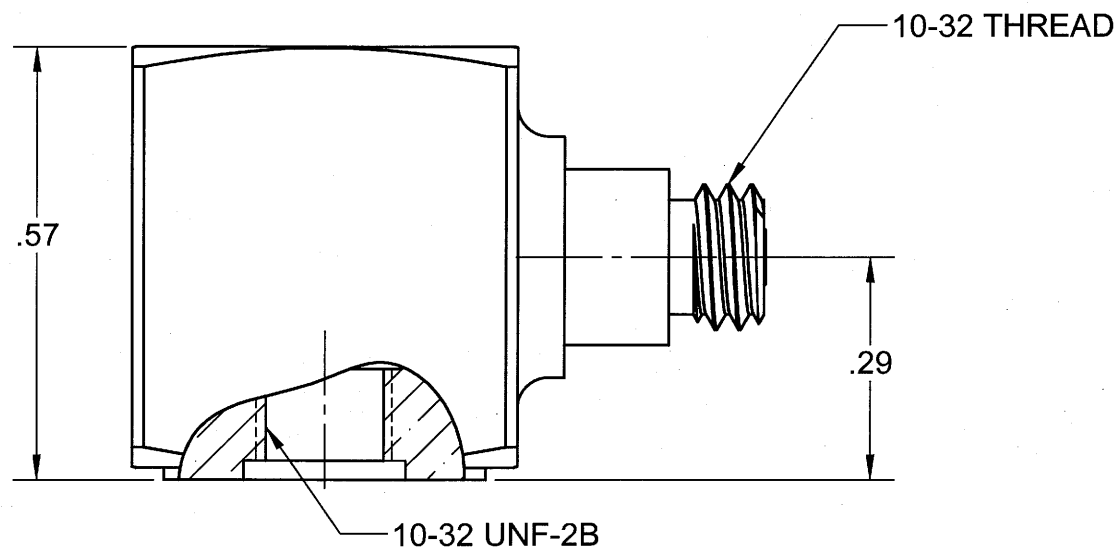
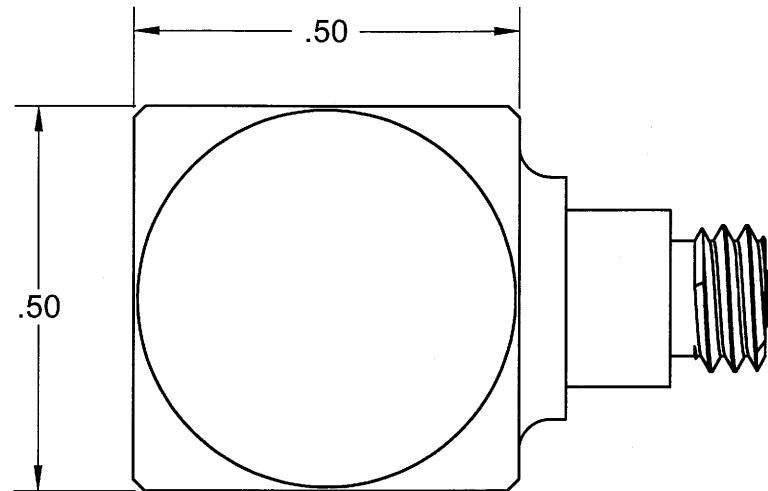
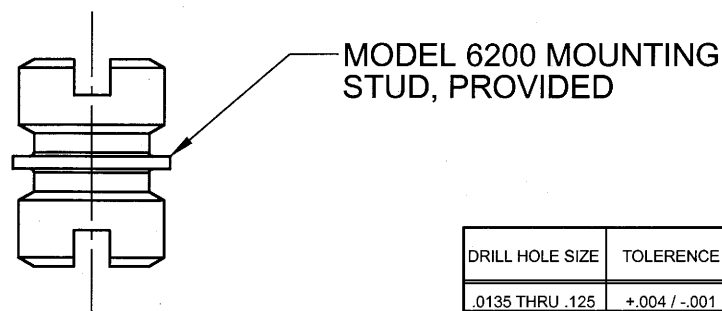

DRILL HOLE SIZE	TOLERANCE	UNLESS OTHERWISE SPECIFIED: INTERPRET DIM & TOL PER ASME Y14.5M - 1994. REMOVE BURRS. COUNTERSINK INTERNAL THDS 90° TO MAJOR DIA. CHAM EXT THDS 45° TO MINOR DIA. THD LENGTHS AND DEPTHS ARE FOR MIN FULL THDS. THDS PER MIL-S-7742. DIMENSIONS APPLY AFTER FINISHING ALL MACHINED SURFACES. TOTAL RUNOUT WITHIN .005. BREAK SHARP EDGES .005 TO .010. MACHINED FILLET RADII .005 TO .015. WELDING SYMBOLS PER AWS A2.4. ABBREVIATIONS PER MIL-STD-12.
.0135 THRU .125	+ .004 / - .001	
.1260 THRU .250	+ .005 / - .001	
.2510 THRU .500	+ .006 / - .001	
.5010 THRU .750	+ .008 / - .001	
.7510 THRU 1.000	+ .010 / - .001	
1.001 THRU 2.000	+ .012 / - .001	

THIRD ANGLE PROJECTION
USA

UNLESS OTHERWISE SPECIFIED:
DIMENSIONS ARE IN INCHES.
TOLERANCES ARE:
DECIMALS .XX ± .010
.XXX ± .005
ANGLES ± 1°

CONTRACT NO.

APPROVALS		DATE
ORIG	JS	01/15/08
CHK	PA	1/15/08
APP		
APP	PML	1/18/08

MATERIAL:
Ti 6Al-4V

FINISH:

DO NOT SCALE DRAWING



MASTER
ONLY IF IN RED

TITLE:
**OUTLINE DRAWING
MODEL 3214AT**

SIZE	CAGE CODE	DWG NO	REV
B	2W033	127-3214AT	A

SCALE: 2:1 SOLIDWORKS SHEET 1 of 1

Model Number 3214A1T	PERFORMANCE SPECIFICATIONS	DOC NO PS3214A1T
--------------------------------	-----------------------------------	----------------------------

IEPE ACCELEROMETER

REV A, ECN 12442, 01/21/16



- HERMETICALLY SEALED
- IDEAL LOW FREQUENCY RESPONSE
- TEDS

This family also includes:

Model	Sensitivity (mV/g)	Frequency Response (Hz)	Time Constant (Sec)	Operating Temp (°F)
3214A2T	100	1 to 10000	0.5 to 1.5	-60 to +250
3214A3T	500	1 to 10000	0.5 to 1.5	-60 to +225

Refer to the performance specifications of the products in this family for detailed description

PHYSICAL

Weight
Connector Type
Mounting Provision
Material, Housing/Connector
Sensing Element
Element Style

ENGLISH		SI	
0.35	oz	10	grams
10-32		10-32	
10-32 X .150 ↓		10-32 X .150 ↓	
Titanium		Titanium	
Ceramic		Ceramic	
Planar Shear		Planar Shear	

PERFORMANCE

Sensitivity, ± 5% [1]
Range for ± 5 Volts Output
Frequency Response, ± 10%
Resonant Frequency
Broad Band Resolution
Linearity [2]
Maximum Transverse sensitivity
Strain Sensitivity @ 250µε

10	mV/g	1	mV/m/s ²
500	g	4905	m/s ²
1 to 10000	Hz	1 to 10000	Hz
> 36	kHz	> 36	kHz
0.0040	Grms	0.039	m/s ² rms
± 1	% F.S.	± 1	% F.S.
5	%	5	%
0.002	g/µε	0.02	m/s ² /µε

ENVIRONMENTAL

Maximum Vibration
Maximum Shock
Operating Temperature Range
TEDS Operating Temperature
Seal

600	Gpeak	5886	m/s ² peak
5000	Gpeak	49050	m/s ² peak
-60 to +250	°F	-51 to 121	°C
-40 to +185	°F	-40 to +85	°C
Hermetic		Hermetic	

ELECTRICAL

Supply Current Range [3]
Compliance Voltage Range
Output Impedence, Typ
Bias Voltage
Discharge Time Constant
TEDS

2 to 20	mA	2 to 20	mA
18 to +30	Volts	18 to +30	Volts
100	Ω	100	Ω
11 to 13	VDC	11 to 13	VDC
0.5 to 1.5	Sec	0.5 to 1.5	Sec
IEEE 1451.4		IEEE 1451.4	

Supplied Accessories:

- 1) Accredited calibration certificate (ISO 17025)
- 2) Model 6200 mounting stud, qty 1

Notes:

- [1] Measured at 100Hz, 1 Grms per ISA RP 37.2.
- [2] Measure using zero-based straight line method, % of F.S. or any lesser range.
- [3] Do not apply power to this system without current limiting, 20 mA MAX. To do so will destroy the IC charge amplifier.
- [4] In the interest of constant product improvement, we reserve the right to change specifications without notice.

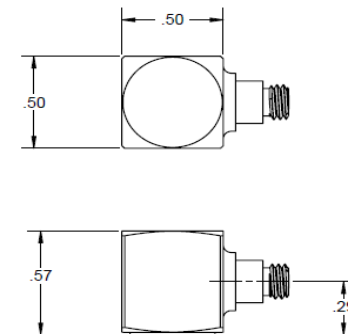
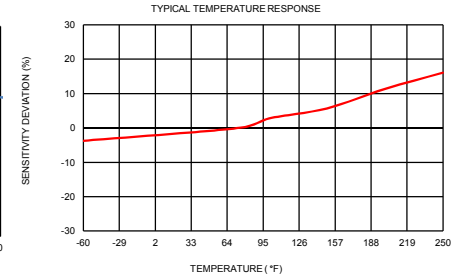
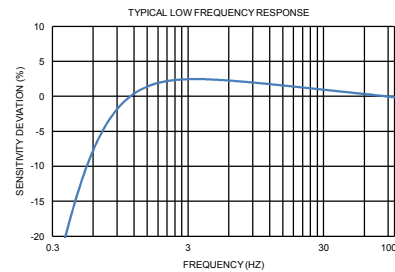

Units on the line drawing are in inches, units in brackets are in millimeters. Refer to 127-3214AT for more information.



21592 Marilla Street, Chatsworth, California 91311 Phone: 818.700.7818 Fax: 818.700.7880 www.dytran.com
For permission to reprint this content, please contact info@dytran.com