

PROPRIETARY AND CONFIDENTIAL

THE INFORMATION CONTAINED IN THIS DRAWING IS THE SOLE PROPERTY OF DYTRAN INSTRUMENTS INC. ANY REPRODUCTION IN PART OR AS A WHOLE WITHOUT THE WRITTEN PERMISSION OF DYTRAN INSTRUMENTS INC. IS PROHIBITED

REVISIONS

REV.	ECN	DESCRIPTION	BY/DATE	CHK	APPR
E	11055	UPDATED VIEWS. CONVERTED TO SOLIDWORKS	EC 07/02/14	JLS	

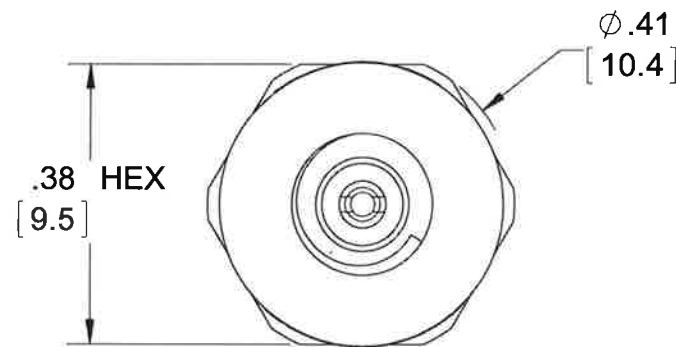

VIEW A-A

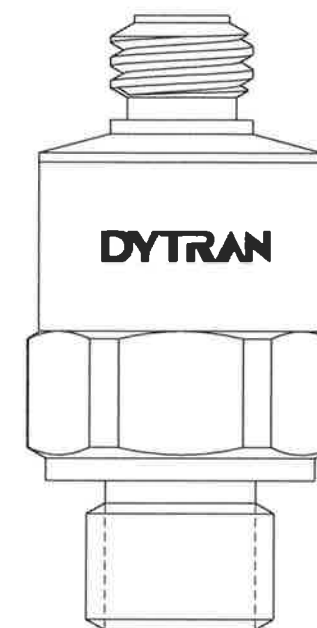
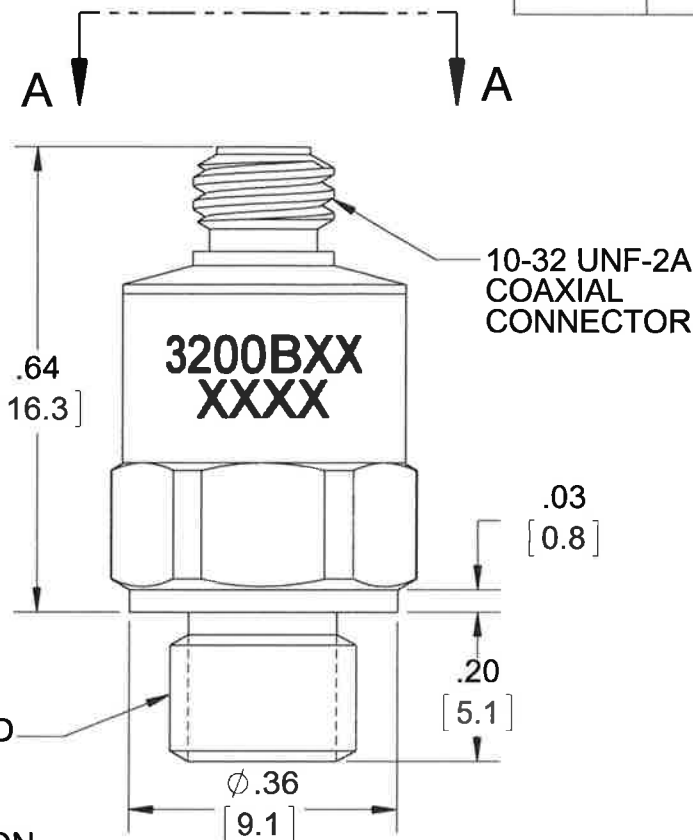
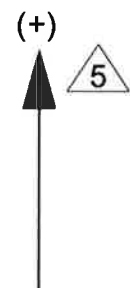

MOUNTING HOLE PREPARATION
 TAP 1/4-28 UNF-2B X .25 [6.4] MIN DEPTH
 OF PERFECT THREAD. HOLE TO BE
 PERPENDICULAR WITHIN ±1°

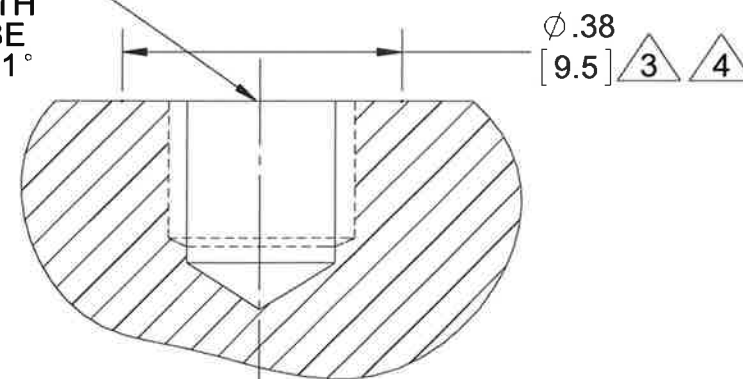

3200B SERIES

5 ARROW INDICATES SENSE AND DIRECTION OF
 ACCELERATION FOR POSITIVE - GOING OUTPUT SIGNAL

4 PREPARE FLAT SURFACE TO THIS DIA. WITH A FINISH OF
 OR BETTER AND FLAT TO .001 TIR.

3 PREPARE MOUNTING SURFACE AS SHOWN.
 APPLY A LAYER OF SILICONE GREASE TO MOUNTING
 SURFACE. TORQUE IN PLACE WITH 50 LB-IN.

2. HOUSING MATERIAL: 17-4 PH STAINLESS STEEL

1. WEIGHT: 6 GRAMS MAX

NOTES: UNLESS OTHERWISE SPECIFIED

UNLESS OTHERWISE SPECIFIED: INTERPRET DIM & TOL PER ASME Y14.5M - 1994. REMOVE BURRS. COUNTERSINK INTERNAL THDS 90° TO MAJOR DIA. CHAM EXT THDS 45° TO MINOR DIA. THD LENGTHS AND DEPTHS ARE FOR MIN FULL THDS. DIMENSIONS APPLY AFTER FINISHING. ALL MACHINED SURFACES. TOTAL RUNOUT WITHIN .005. BREAK SHARP EDGES .005 TO .010. MACHINED FILLET RADII .005 TO .015. WELDING SYMBOLS PER AWS A2.4. ABBREVIATIONS PER MIL-STD-12.	UNLESS OTHERWISE SPECIFIED: DIMENSIONS ARE IN INCHES. DIMENSIONS IN BRACKETS [] ARE IN MILLIMETERS TOLERANCES ARE:				
	DECIMALS .XX ±.03 .XXX ±.010	METRIC .X ± 0.8 .XX ± 0.25	ANGLES ±1°	TITLE: OUTLINE/INSTALLATION DRAWING, SERIES 3200B, LIVM, SHOCK ACCELEROMETERS	
	APPROVALS ORIG NC 11/30/81 CHK NC 11/30/81 APP 8/8/14		DATE 11/30/81 8/8/14		SIZE B
	DO NOT SCALE DRAWING		THIRD ANGLE PROJECTION 	CAGE CODE 2W033	DWG NO 127-3200B

MODEL NUMBER 3200B4	PERFORMANCE SPECIFICATION	DOC NO PS3200B4
	SINGLE AXIS ACCELEROMETER, IEPE	REV C, ECN 14019, 02/08/18



**LIGHTWEIGHT
HIGH NATURAL FREQUENCY
BASE ISOLATED**

PHYSICAL

Weight	0.21	oz
Mounting Provision	1/4-28 UNF-2A	
Connector	Coaxial	
Thread	10-32 UNF-2A	
Material Body	17-4 PH S.S.	
Sensing Element	Quartz	
Mode	Compression	

ENGLISH	SI
0.21 oz	6.0 grams
1/4-28 UNF-2A	1/4-28 UNF-2A
Coaxial	Coaxial
10-32 UNF-2A	10-32 UNF-2A
17-4 PH S.S.	17-4 PH S.S.
Quartz	Quartz
Compression	Compression

PERFORMANCE

	ENGLISH	SI
Sensitivity +/- 10% [1]	0.5 mV/g	0.05 mV/m/s ²
Maximum Range F.S.	10000 g	98000 m/s ²
Frequency Response, ± 5%	.50 to 10000 Hz	.50 to 10000 Hz
± 10%	.35 to 20000 Hz	.35 to 20000 Hz
± 3db	.16 to >50000 Hz	.16 to >50000 Hz
Mounted Resonant Frequency	> 90 kHz	> 90 kHz
Electrical Noise	0.14 Grms	1.4 m/s ² rms
Linearity [2]	± 1% %F.S	± 1% %F.S
Transverse Sensitivity, Max.	3 %	3 %

ENVIRONMENTAL

	ENGLISH	SI
Maximum Shock (peak)	± 50000 G peak	± 490500 m/s ² peak
Temperature Range	-60 to +250 °F	-51 to +121 °C
Seal	Epoxy	Epoxy

ELECTRICAL

	ENGLISH	SI
Power Supply [3]	2 to 20 mA	2 to 20 mA
Compliance Voltage Range	+18 to +30 V	+18 to +30 V
Output Impedance	100 Ω	100 Ω
Bias Voltage	+7.5 to +9.5 VDC	+7.5 to +9.5 VDC
Discharge Time Constant	1 to 1.5 sec	1 to 1.5 sec
Electrical Isolation [4]	10 GΩ	10 GΩ
Grounding	Base Isolated	Base Isolated

This family also includes:

Model	Sensitivity (mV/g)	Range (Gpeak)	Resolution (Grms)	Oper. Temp(°F)	Time Constant (Sec)
3200B	0.05	70000	1.4	-60 to +250	1.0 to 1.5
3200B2	0.1	50000	0.7	-60 to +250	1.0 to 1.5
3200B3	0.25	20000	0.28	-60 to +250	1.0 to 1.5
3200B5	1.0	5000	0.07	-60 to +250	1.0 to 1.5
3200B6	2.0	2500	0.035	-60 to +250	1.0 to 1.5

Refer to the performance specifications of the products in this family for detailed description.

Supplied Accessories:

- 1) Accredited calibration certificate (ISO 17025)

Notes:

- [1] Measured at 100 Hz, 1 GRMS per ISA RP 37.2.
- [2] Measured using zero-based best straight-line method, % of F.S. or any lesser range.
- [3] Do not apply power to this device without current limiting, 20 mA MAX. To do so will destroy the integral IC amplifier.
- [4] Case ground to mounting surface.

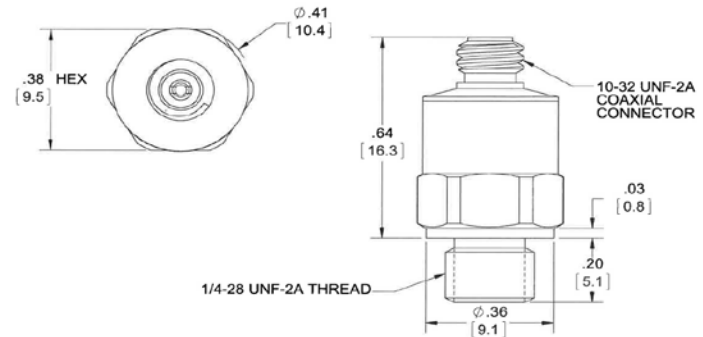
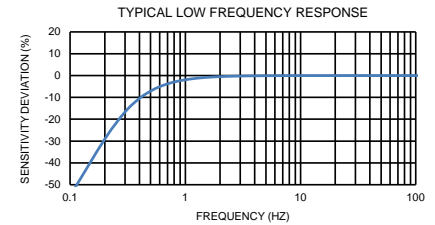
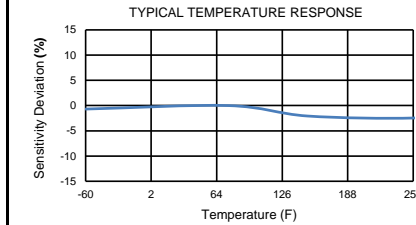

Units on the line drawing are in inches, units in brackets are in millimeters. Refer to 127-3200B for more information.



21592 Marilla Street, Chatsworth, California 91311 Phone: 818.700.7818 Fax:818.700.7880 www.dytran.com For permission to reprint this content, please contact info@dytran.com